



Control[®] 1 Pro

Two-Way Professional Compact Loudspeaker System

Professional Series

Key Features:

- ▶ 150 Watts Continuous Power Handling
- ▶ Professional Drivers and Crossover Network
- ▶ Included Mounting Bracket
- ▶ Transparent and Faithful Sonic Performance
- ▶ Magnetically Shielded Transducers
- ▶ SonicGuard™ Overload Protection
- ▶ Available in Black or White Finishes

Applications:

Representing the next-generation in professional high-performance, compact loudspeaker systems, the Control[®] 1 Pro builds on its proud heritage while incorporating the latest innovations in JBL Professional loudspeaker systems design. Featuring proven JBL transducer technologies, the Control 1 Pro is perfect for a wide variety of critical near-field audio applications.

With independent, monitor-grade high and low frequency drivers, the Control 1 Pro's professional crossover network provides steep slopes for exceptional sonic performance and incorporates full-range SonicGuard™ overload protection into the design ensuring network and transducer protection from excessive power surges from the amplifier.

The Control 1 Pro's rugged and durable molded enclosure houses magnetically shielded transducers making it ideal for use with video and computer monitors or other magnetically sensitive equipment. Moreover, the Control 1 Pro's compact design makes it ideal for audio-visual applications, computer workstations, recording and broadcast studios, mobile audio-video control rooms and foreground and background music.

The Control 1 Pro can easily be mounted against a wall or other flat surface with the enclosed brackets or simply used as a bookshelf speaker.



Specifications:

System:

Frequency Range (-10 dB): 80 Hz - 20 kHz
Frequency Response (+/- 3 dB): 100 Hz - 18 kHz
Power Capacity ¹ : 150 W
Sensitivity ² : 87 dB SPL, 1 W 1 m (3.3 ft)
Maximum SPL ³ : 108 dB continuous, 114 dB peak
Directivity Factor (Q) ² : 6.0
Directivity Index (DI): 7.8 dB
Nominal Impedance: 4 ohms
Crossover Frequency: 4.2 kHz
Overload Protection: Full-range SonicGuard™ power limiting to protect network and transducers

Transducers:

LF Driver: 135 mm (5.25 in) low frequency loudspeaker
HF Driver: 19 mm (.75 in) polycarbonate dome tweeter
Input Connectors: Spring-loaded terminals

Enclosure:

Enclosure Material: Polypropylene Structural Foam
Finish: Black (C1Pro) or White (C1Pro-WH)
Dimensions: 235 mm x 159 mm x 143 mm (9.3 in x 6.3 in x 5.6 in)
Net Weight (each): 1.8 kg (4 lb)
Shipping Weight (pair): 4.6 kg (10 lb)
Included Accessories: Mounting Bracket Assembly
Optional Accessories: MTC-1A ultra-duty mount bracket MTC-8 heavy-duty mounting bracket

¹IEC Standard, full bandwidth pink noise with 6 dB crest factor; 2 hour duration.

²Average 1 kHz to 10 kHz

³Calculated based on power rating and sensitivity, exclusive of power compression.

JBL continually engages in research related to product improvement. Some materials, production methods and design refinements are introduced into existing products without notice as a routine expression of that philosophy. For this reason, any current JBL product may differ in some respect from its published description, but will always equal or exceed the original design specifications unless otherwise stated.

▶ Control 1 Pro Two-Way Professional Compact Loudspeaker

Beamwidth:

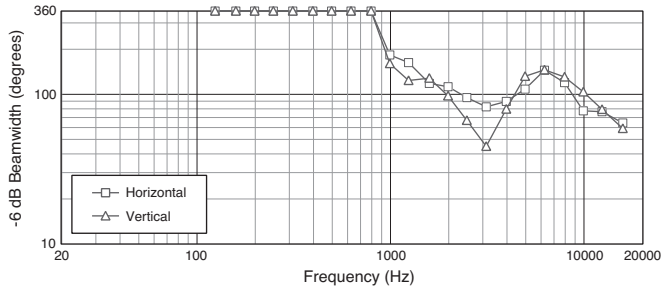

Directivity Index:

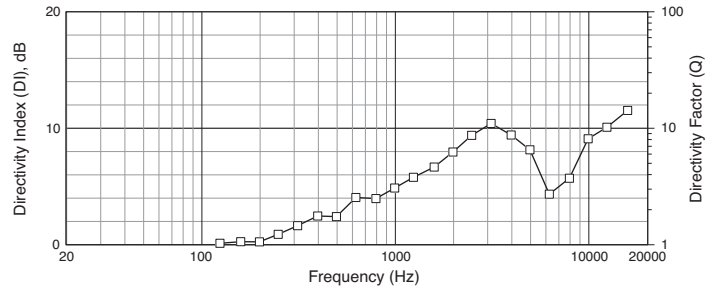

Frequency Response:

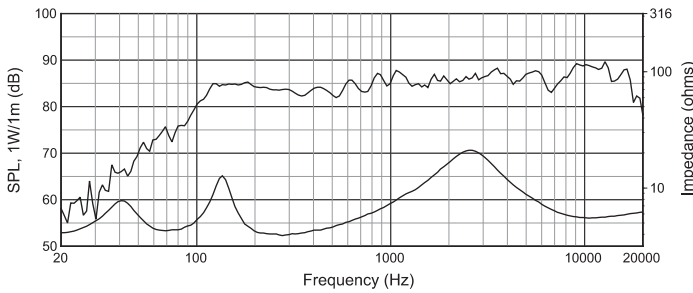

Horizontal Off-Axis Frequency Response:

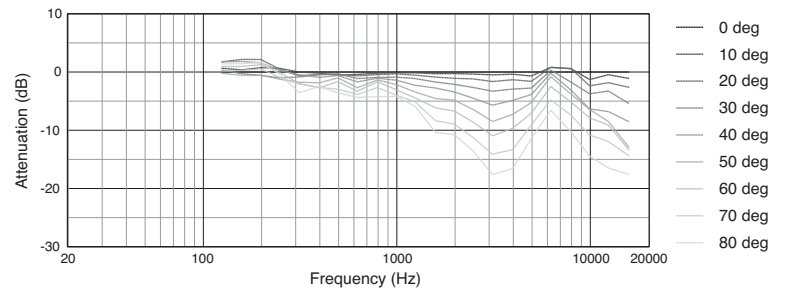

Dimensions:

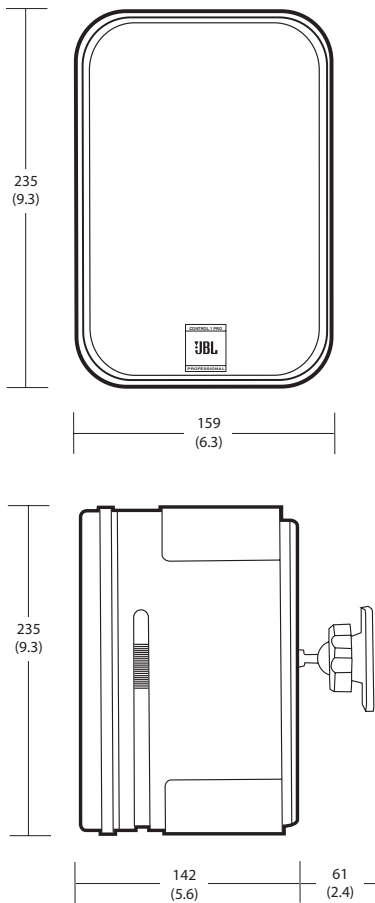

Dimensions in mm (in)

Mounting Bracket:

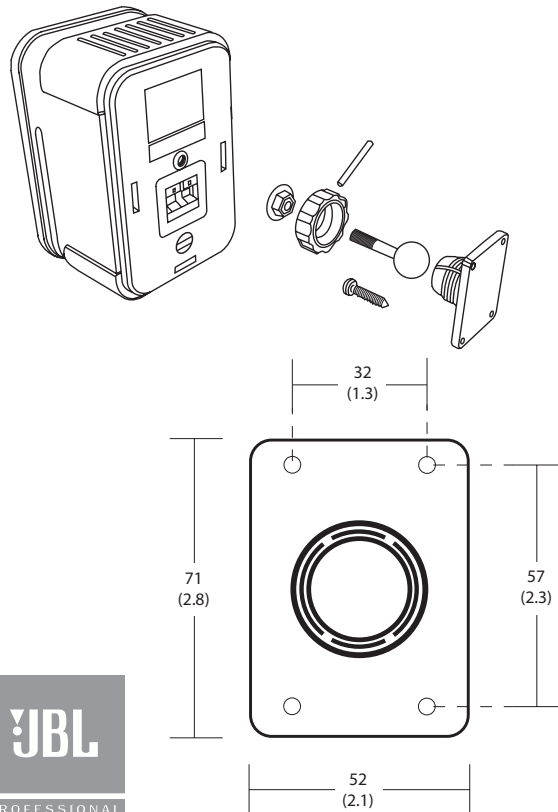

JBL Professional
8500 Balboa Boulevard, P.O. Box 2200
Northridge, California 91329 U.S.A.

■ A Harman International Company
© Copyright 2006 JBL Professional

SS C1P
CRP 5M
08/06



Control 5TM Compact Control Monitor Loudspeaker

Professional Series

Key Features:

- ▶ Sensitivity: 89 dB SPL, 1 W, 1 m (3.3 ft)
- ▶ High power handling (175 W pink noise) with integral protection circuit network
- ▶ Molded enclosure with shielded magnet structure
- ▶ Components:
 - 165 mm (6½ in) low frequency loudspeaker
 - 25 mm (1 in) pure titanium dome tweeter
- ▶ Optional mounting hardware
Available in two colors: black and white

The Control 5TM is a high performance, wide range control monitor suitable for use as the primary sound source in a variety of applications.

Smooth, extended frequency response combines with wide dynamic capabilities to provide acoustic performance that makes the Control 5 ideal for recording studios, audio-video control rooms, remote trucks and broadcast studios. Clean, functional visual design makes the Control 5 also ideal for foreground music systems, moderate level sound reinforcement, discotheques and music playback systems.

A 165 mm (6½ in) low frequency driver provides solid, powerful bass response to 50 Hz. High frequency response to 20 kHz is handled by a pure titanium 25 mm (1 in) dome. Both transducers are magnetically shielded, allowing for use in close proximity to video monitors. The dividing network incorporates protection circuitry to prevent system damage and utilizes high quality components including bypass capacitors for outstanding transient accuracy.

Molded of dense polypropylene foam, with a finish of black, gray or white, the Control 5 enclosure offers a pleasing shape that fits easily into any environment. Wall, ceiling, rack and tripod mounting systems allow positioning of the system in exactly the right spot for optimum performance.



Specifications:

SYSTEM:	
Frequency Response (± 3 dB):	75 Hz to 20 kHz
Power Capacity ¹ :	175 W
Sensitivity ² :	89 dB SPL, 1 W, 1 m (3.3 ft)
Directivity Factor (Q):	2.8
Directivity Index (DI):	4.5
Nominal Impedance:	4 ohms
Crossover Frequency:	3 kHz
Polarity:	Positive Voltage to + terminal causes outward low frequency cone motion,
GENERAL:	
Enclosure Material:	Polypropylene structural foam
Finish:	Black or white
Dimensions:	387 mm H x 251 mm W x 229 mm D 15¼ in H x 9 7/8 in W x 9 in D
Net Weight (each):	4.5 kg (10 lbs)
Shipping Weight (pair):	11 kg (24 lbs)
ACCESSORIES:	
MTC-51 Wall Mount Bracket:	Allows the Control 5 to be mounted to any rigid vertical surface with a unique polymer ball and clamp design. In addition to omnidirectional movement about the ball, the speaker's connecting wires may be run internal to the clamp. Optional colors.
MTC-52 Ceiling Mount Bracket:	The same as the MTC-51 except that it is designed to be mounted to a rigid ceiling surface. Optional colors.
MTC-53 Rack Mount Bracket:	Allows the Control to be mounted in a standard 19 inch EIA equipment rack, with accommodation for vertical adjustment.
MTC-54 Tripod Mounting Adapter:	Allows the Control 5 to be mounted to the JBL MT4612 aluminum tripod in either a vertical or horizontal position.
MTC-56 Wall Mount Bracket:	Low cost, fixed angle wall mount bracket with safety chain.
Note: Accessory attachment points on rear of the enclosure are ¼ x 20 threaded brass bushings,	

¹Rating based on test signal of IEC filtered random noise with a peak-to-average ratio of 6 dB, two hours duration.

²Sensitivity is based on a swept 500 Hz to 2.5 kHz signal for an input of 2.0 V @ 4 ohms.

JBL continually engages in research related to product improvement. New materials, production methods and design refinements are introduced into existing products without notice as a routine expression of that philosophy. For this reason, any current JBL product may differ in some respect from its published description but will always equal or exceed the original design specifications unless otherwise stated.

▶ Control 5™ Compact Control Monitor Loudspeaker

Architectural Specifications:

The loudspeaker system shall consist of a 165 mm (6½ in) low frequency transducer, 25 mm (1 in) pure titanium dome tweeter, and frequency dividing network installed in a ported enclosure. The magnetic assemblies shall use ferrite magnets, with integral shielding of the external magnetic field. The low frequency voice coil shall be 25 mm (1 in) in diameter. The frequency dividing network shall have a crossover frequency of 3 kHz and shall utilize polypropylene bypass capacitors to reduce hysteresis effects on the signal.

Performance specifications of a typical production unit shall be as follows: measured sensitivity (SPL at 1 m (3.3 ft) with 2.0 V input, swept from 500 Hz to 2.5 kHz) shall be at least 89 dB SPL. Frequency response shall be within plus or minus 3 dB from 75 Hz to 20 kHz. Usable frequency response shall extend downward to 50 Hz. Nominal impedance shall be 4 ohms. Rated power capacity shall be at least 175 watts continuous pink noise, based on a test signal of filtered random noise conforming to international standard IEC 268-5 (pink noise with 12 dB/octave rolloff below 40 Hz and above 5 kHz with a peak-to-average ratio of 6 dB), two hours duration.

The entire enclosure shall be manufactured of molded polypropylene structural foam. Optional mounting brackets shall be available for positioning of the loudspeaker at various angles for both temporary and permanent installations. Overall dimensions shall be no greater than 387 mm (15¼ in) by 251 mm (9 7/8 in) by 229 mm (9 in) deep. Finish shall be black or white, with metal grille and rubber end protectors.

The system shall be the JBL Model Control 5.

Frequency Response at 1 W (2.83 V), 1 meter; Impedance

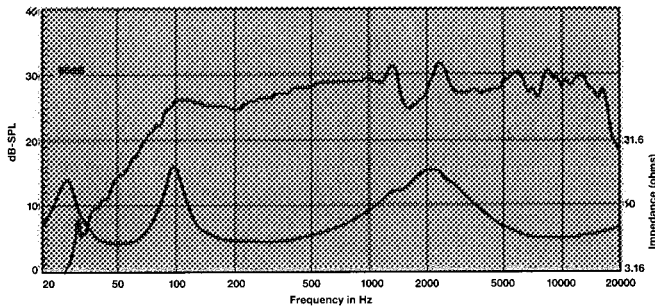

Horizontal and Vertical Beamwidth (-6 dB) vs. Frequency

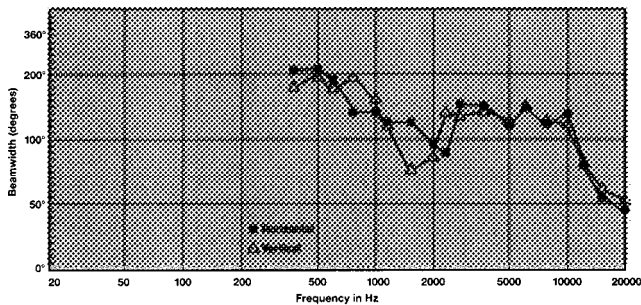

Directivity vs. Frequency

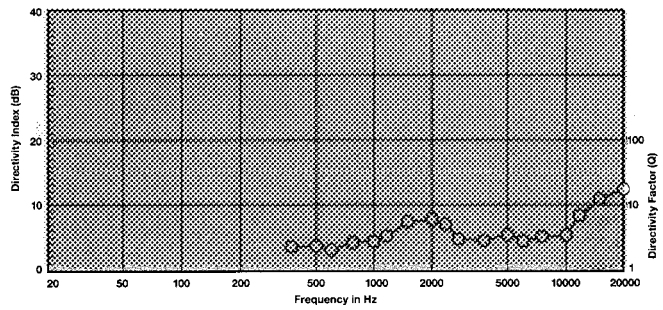

Distortion vs. Frequency 10 W Distortion Raised 20 dB

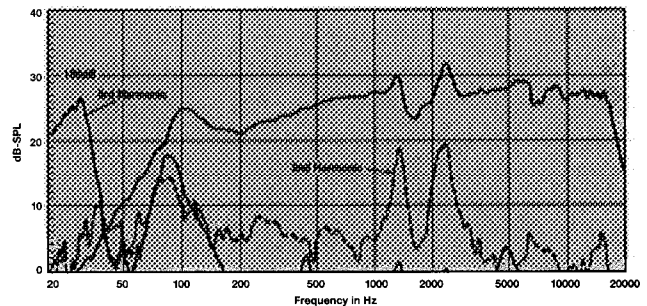

JBL Professional
8500 Balboa Boulevard, P.O. Box 2200
Northridge, California 91329 U.S.A.
H A Harman international Company

SS CONTROL 5
CRP 10M
5/97